

NOTE:

MATERIAL: CONCRETE 35MPa @ 28DAYS, NON-SULFATE
 CONSTRUCTION: MEETS CSA B66-21
 MONOLITHIC CAST DIVIDER WALL
 TOTAL WEIGHT: 6982 kg (15392 lbs)
 TOTAL VOLUME: 10356 L (2278 Imp. Gal.)
 WORKING VOLUME: 9062 L (1994 Imp. Gal.) @ 64 [1626] LIQUID DEPTH
 INLET/OUTLET: POLYLOK POLY IV PIPE SEAL
 INLET BAFFLE: Ø 4.0[100MM] PVC SANITARY TEE & 4[100MM] STUB
 OUTLET BAFFLE/FILTER: POLYLOK PL250 FILTER HOUSING & CARTRIDGE ASSEMBLY: AT MANUFACTURERS FACILITY
 MAXIMUM BURIAL DEPTH: 47.24" [1.2M]
 DIMENSIONS: INCHES [MM]

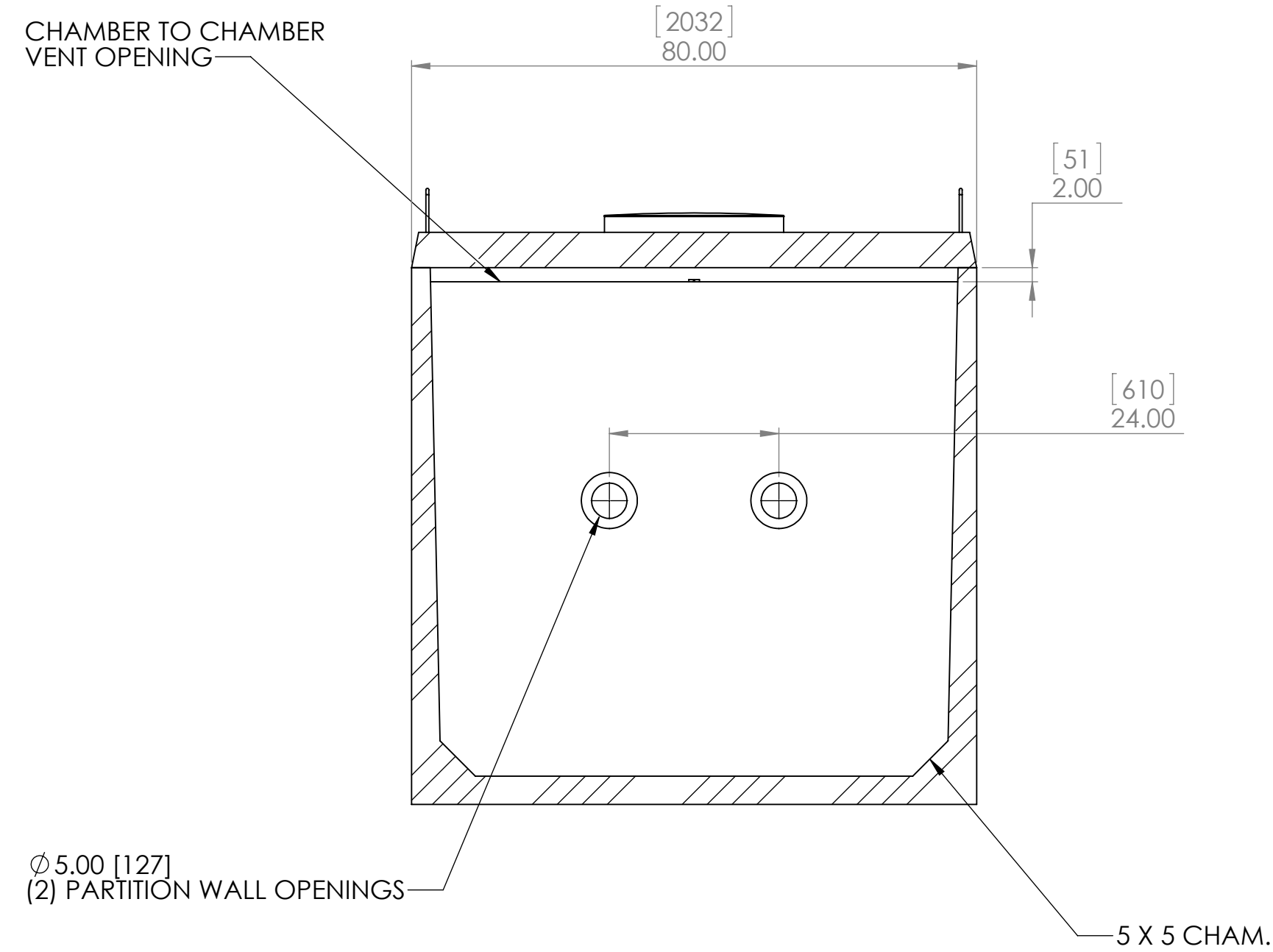

SECTION P-P

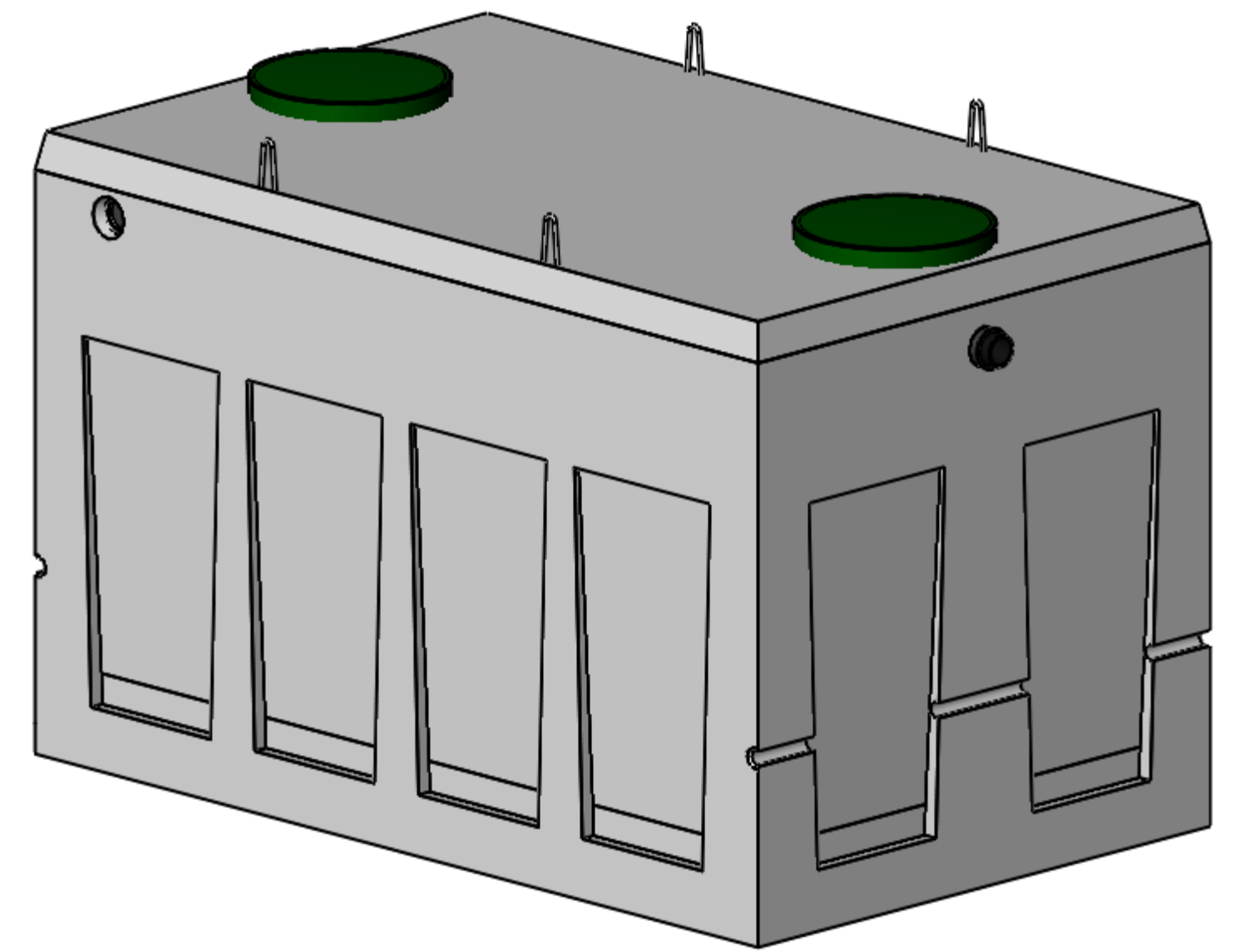
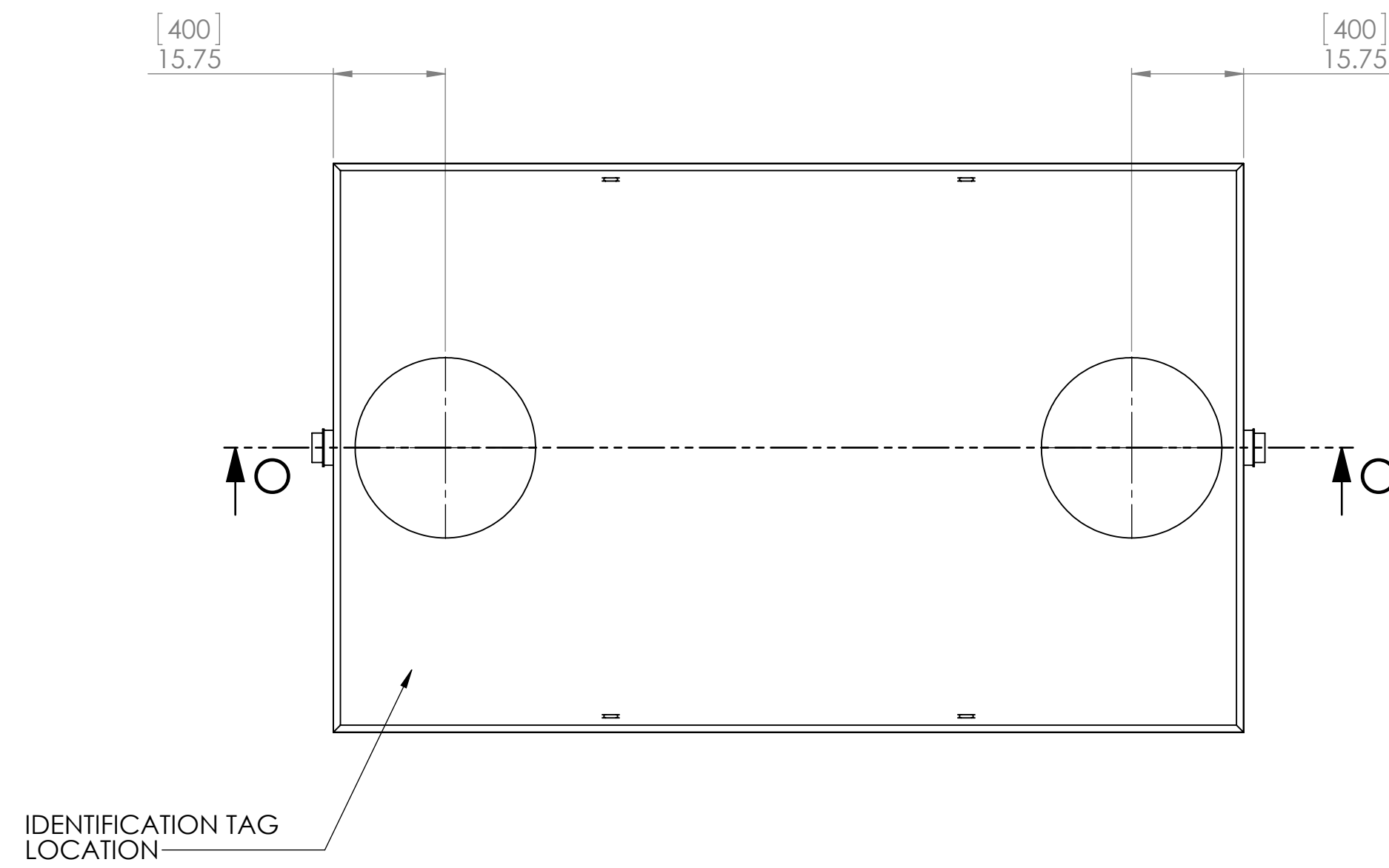
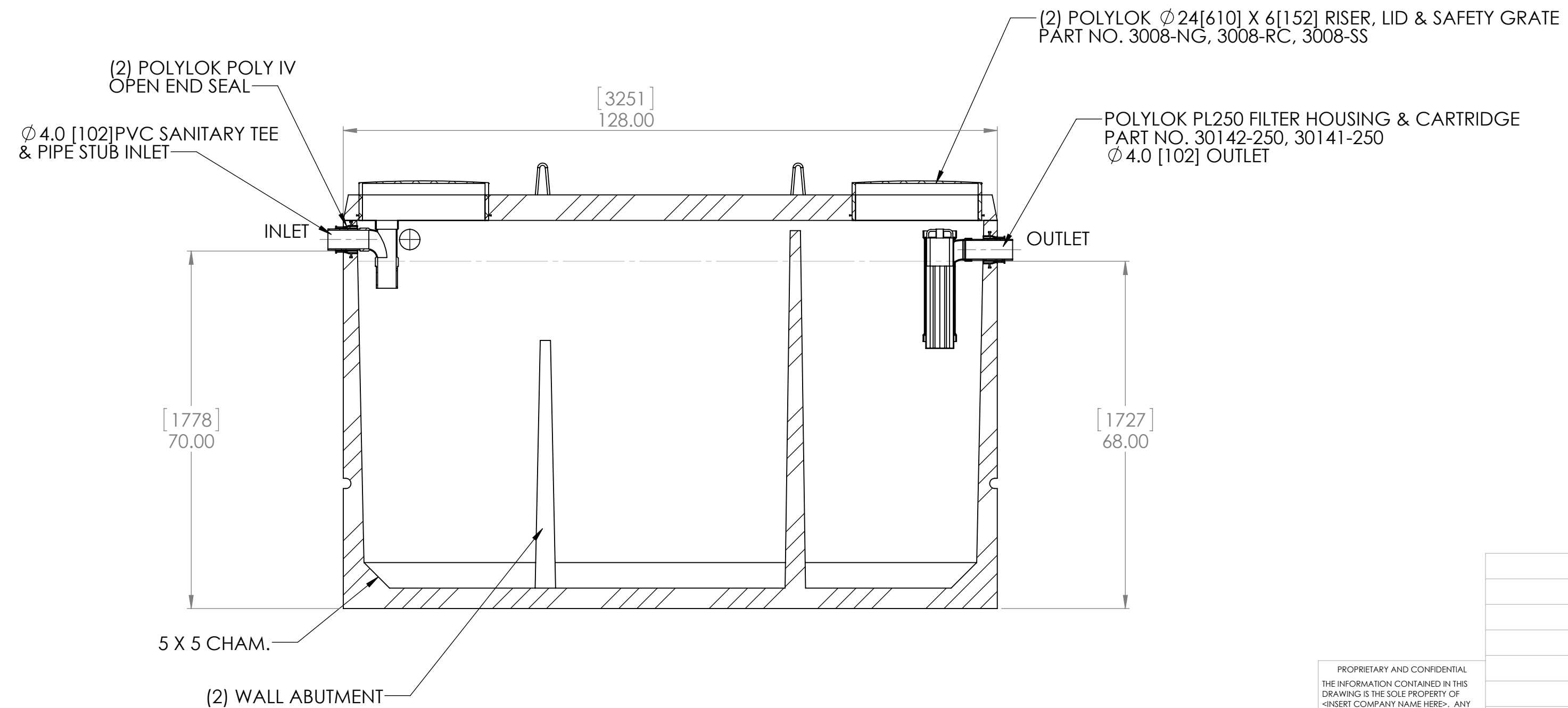
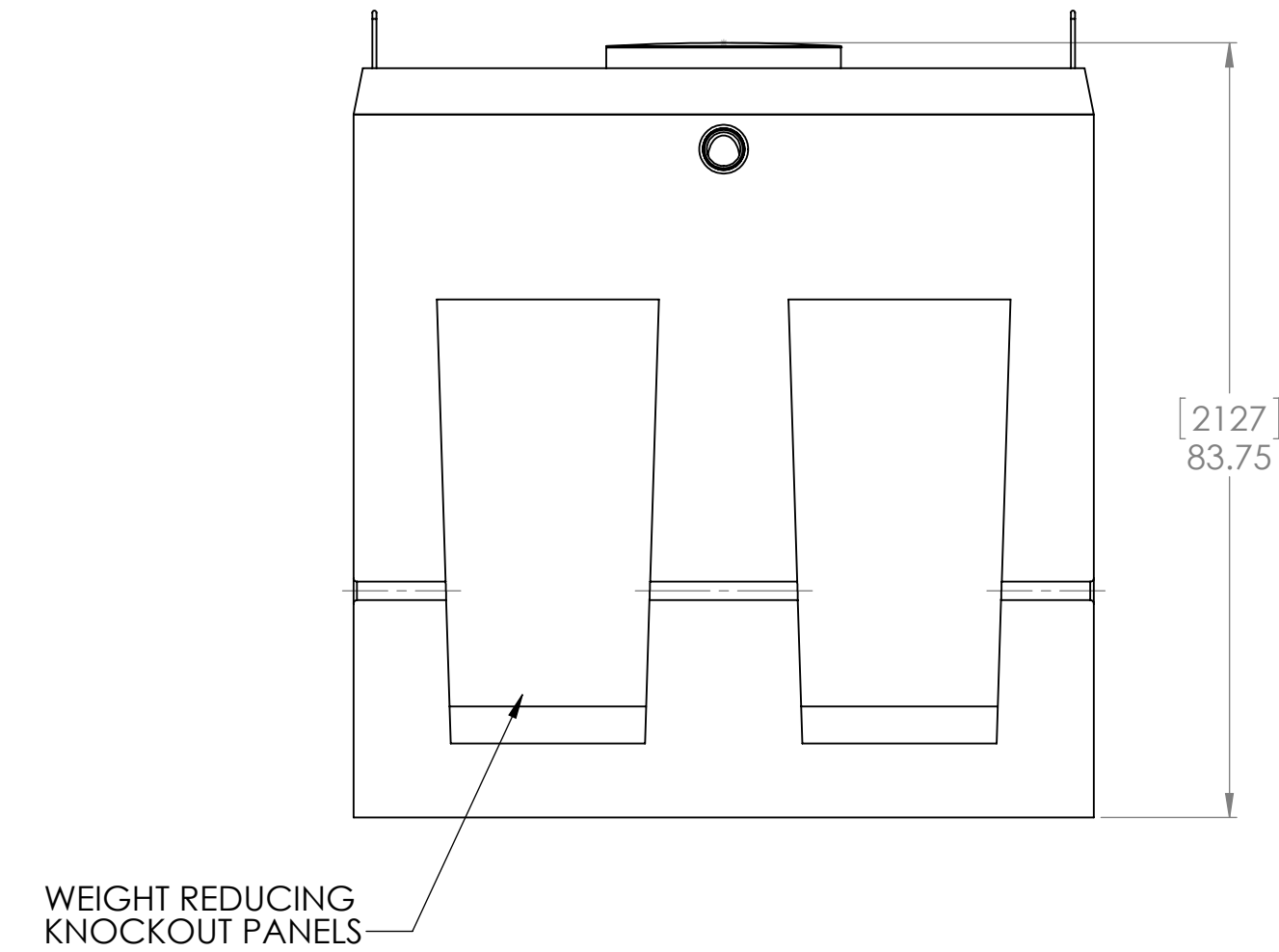
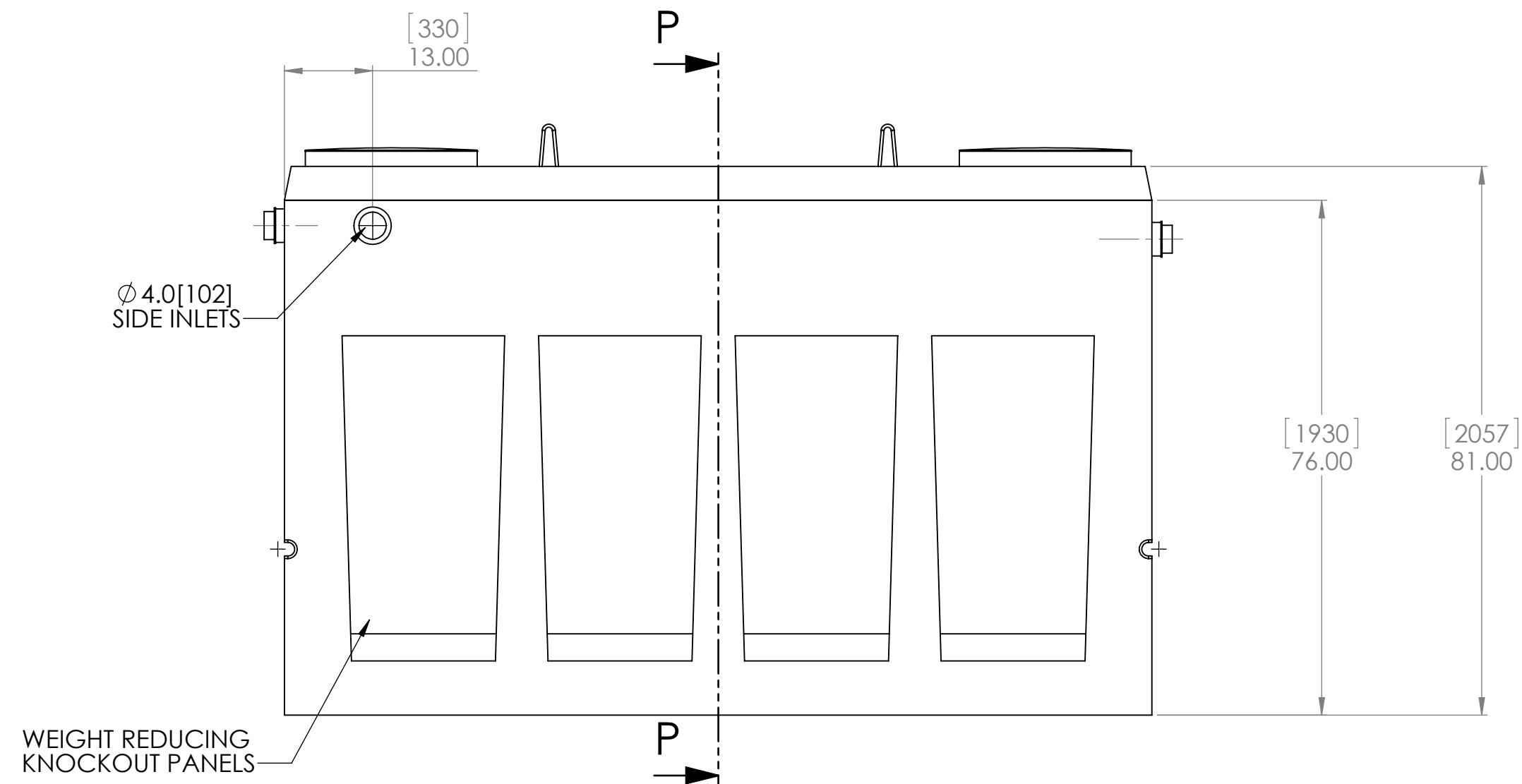

SECTION O-O

PROPRIETARY AND CONFIDENTIAL
 THE INFORMATION CONTAINED IN THIS DRAWING IS THE SOLE PROPERTY OF REID'S PRECAST CEMENT PRODUCTS LTD. ANY REPRODUCTION IN PART OR AS A WHOLE WITHOUT THE WRITTEN PERMISSION OF REID'S PRECAST CEMENT PRODUCTS LTD. IS PROHIBITED.

UNLESS OTHERWISE SPECIFIED:		NAME	DATE	REID'S PRECAST CEMENT PRODUCTS LTD LANGTON, ONTARIO, CANADA 519 875-2121
DRAWN				
CHECKED				
ENG APPR.				
MFG APPR.				TITLE: 9000L SEPTIC TANK
G.A.				
COMMENTS:				SIZE DWG. NO. REV D ST9000L A
NEXT ASSY USED ON FINISH				
APPLICATION				SCALE: 1:20 WEIGHT: SHEET 1 OF 1